

## Common Methods of Backflow Prevention

### AIR GAP

**Description:** An approved air gap is a method of backflow prevention that means the physical separation between the end of the water supply pipe (example: faucet) and open vessel (example: sink). Also referred to by Virginia Department of Health's new term "**Backflow Elimination Method**". When implemented correctly, backflow cannot occur.

**Installation and testing requirements:** The separation must be twice the supply pipe inside diameter but never less than one inch. An air gap or physical disconnection gives the highest degree of protection and shall be used whenever practical in **high hazard** situations subject to backpressure. Since the application of air gaps is limited, other backflow protection systems can be used.



### REDUCED PRESSURE ZONE ASSEMBLY (RP)

**Description:** The Reduced Pressure Zone Assembly is a mechanical device consisting of two independent check valves and a differential pressure relief valve, which automatically relieves excess pressure. Has test cocks and shutoff valves on each end of the device.

**Typical use:** The reduced pressure zone backflow preventer controls direct and indirect cross-connections it's also used to isolate potable water from non-potable water lines. Used for **low and high hazard** risks, the reduced pressure zone backflow preventer provides the highest level of protection.

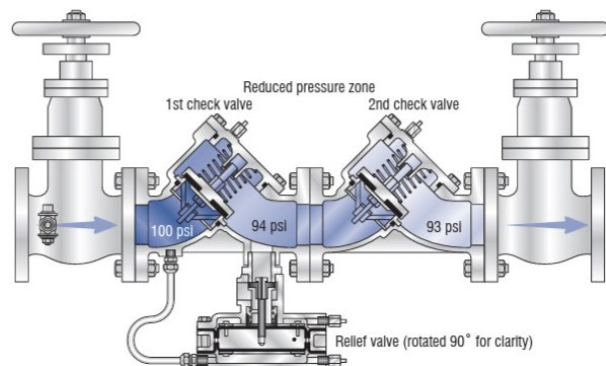

**Installation and testing requirements:** Due to certain combinations of check valve failure and/or system backpressure cause the relief valve to discharge, the device must be mounted in a location where the drain will not become flooded. Annual testing is required. This device can be installed either horizontally or vertical, per manufacturer recommendation.

### DOUBLE CHECK VALVE ASSEMBLY (DC)

**Description:** The Double Check Valve assembly is a mechanical device consisting of two single independently acting check valves. Has test cocks and shutoff valves at each end of the device.

**Typical use:** The double check backflow preventer can only be used in **low hazard** situations. The use of this type of device is to protect against back-siphonage or backflow caused by backpressure.

**Installation and testing requirements:** The Double check valve (DC) must be installed in an accessible location for annual testing. This device can be installed either horizontally or vertical, per manufacturer recommendation.

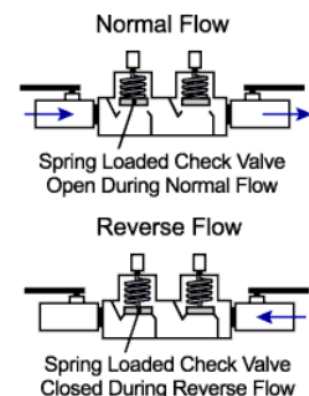

## PRESSURE VACUUM BREAKER ASSEMBLY (PVB)

**Description:** The Pressure Vacuum Breaker is an assembly consisting of one independently operating spring-loaded check valve and a spring-loaded air inlet valve. When supply pressure drops below atmospheric pressure, air pressure opens the air inlet, which breaks the vacuum. The check valve closes simultaneously, preventing backflow from occurring. Has test cocks and shutoff valves on each end of the device.

**Typical use:** Ideal for **low and high hazards** to protect against back-siphonage under continuous pressure, such as irrigation systems and industrial process water systems where the water enters the equipment.

**Installation and testing requirements:** Commonly used in outdoor applications for protection in high or low hazard situations. Will not prevent backflow from backpressure, so it is required to be installed 12 inches above the highest downstream outlet (or above the highest point in the system). Annual testing required.

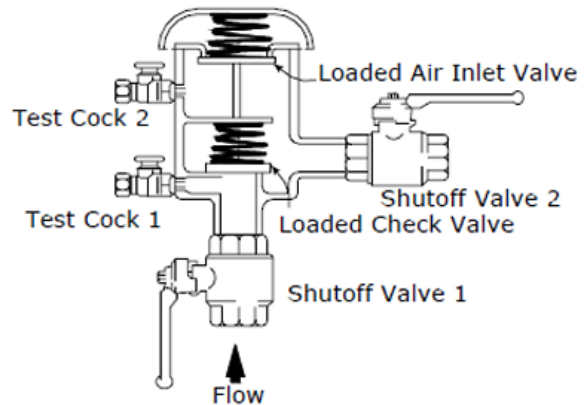

## RESIDENTIAL DUAL CHECK (RDC)

**Description:** The Residential Dual Check provides protection by closing two internal check valves whenever the water flow stops or reverses direction.

**Typical use:** The Residential Dual Check valve is designed for **low hazard** residential water systems.

**Installation and testing requirements:** A Residential Dual Check is installed immediately downstream of the residential water meters, this device is required to be rebuilt or replaced ever 5 years. No annual testing is required.

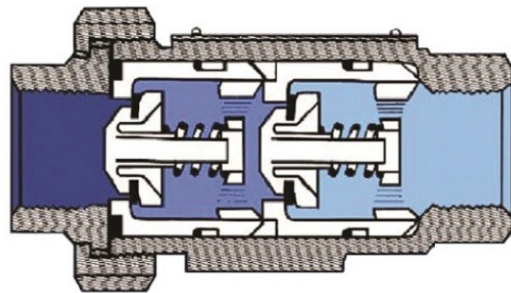

## HOSE CONNECTION VACUUM BREAKER (HVB)

**Description:** The spring-loaded check valve in the HVB does not allow drainage of water from between the hose bib and the upper part of the HVB. This device works to prevent backflow to the water supply by venting water to the atmosphere (onto the ground) when backflow conditions exist. Good for **low and high hazards** of back-siphonage.

**Typical use:** The most common places HVB are installed, are sillcocks (where garden hoses connect), and laundry sink faucets.

**Installation and testing requirements:** Hose connection vacuum breakers are installed on your outside faucets to prevent backflow of contaminated water into the water supply. Cannot be installed where the device will be subject to continuous pressure or back pressure, must be exercised every 12 hours. No annual testing is required.

